

# Popodusche ECO 3.0

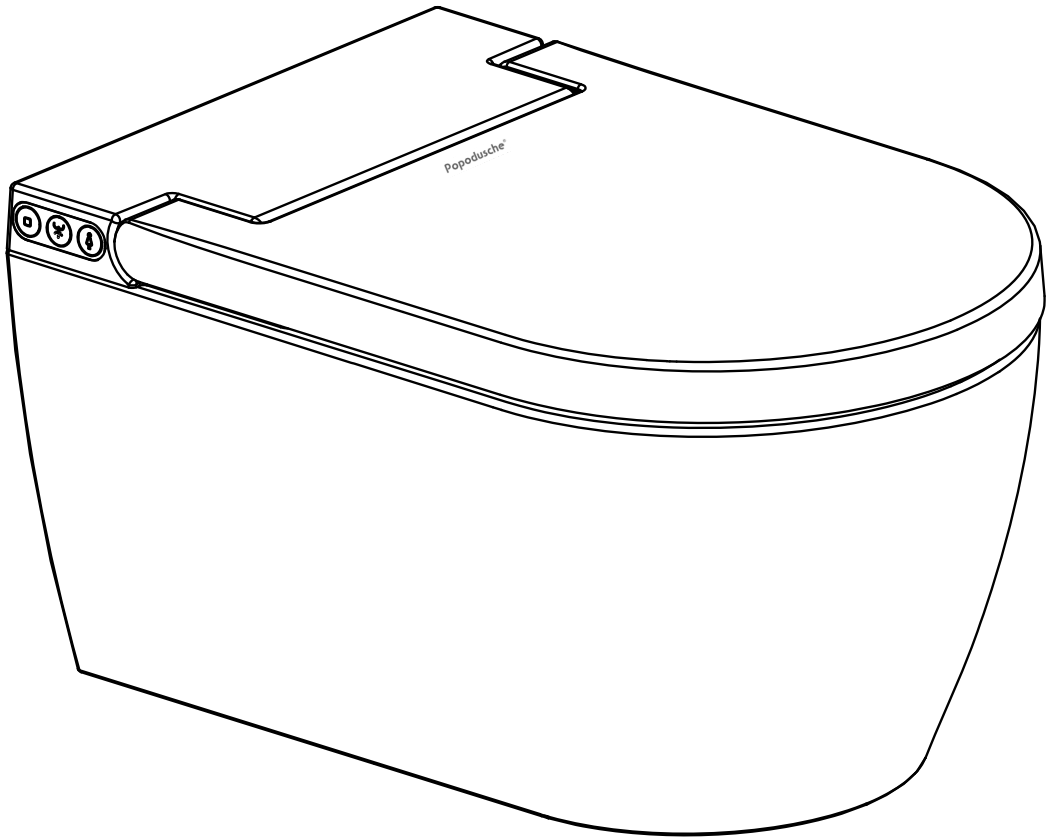

**MONTAGEANLEITUNG /  
INSTALLATION INSTRUCTIONS**

## Information / Info

### Erläuterung der Symbole / Explanation of symbols



**DANGER**

Bezieht sich auf eine potenziell gefährliche Situation, die zu schweren Verletzungen oder zum Tod führen kann.

Refers to potentially dangerous situation that may cause serious injury or death .



**NOTICE**

Verweist auf eine potenziell gefährliche Situation, die zu Verletzungen oder Sachschäden führen kann.

Refers to potentially dangerous situation that may cause injury or property losses.



**FORBID**

Weist auf ein Verbot hin.

Refers to forbidden to do .



**MUST BE  
ABIDED**

Bezieht sich auf das Einhalten der Regeln.

Refers to abide by the rules.

## Lieferumfang / Accessories

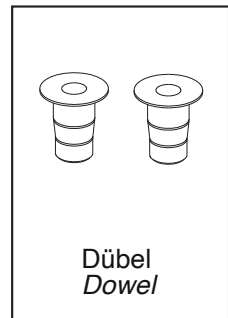
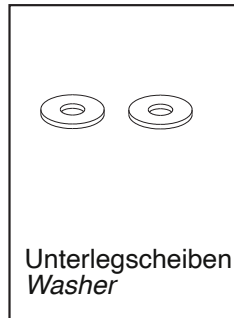
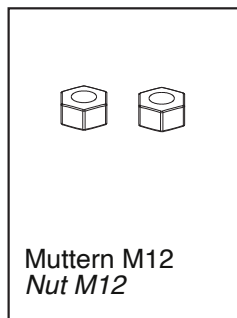
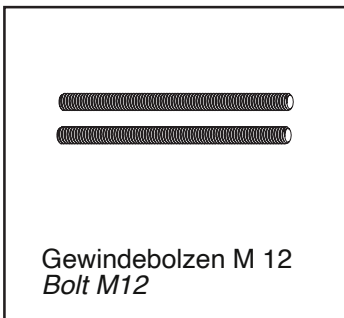
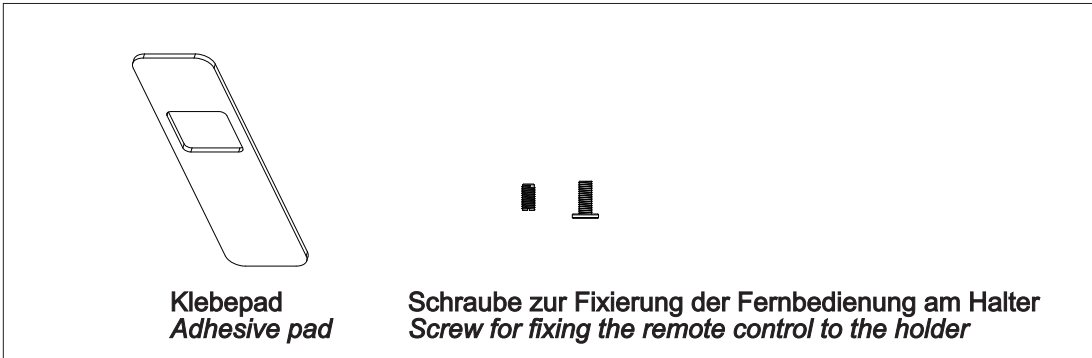
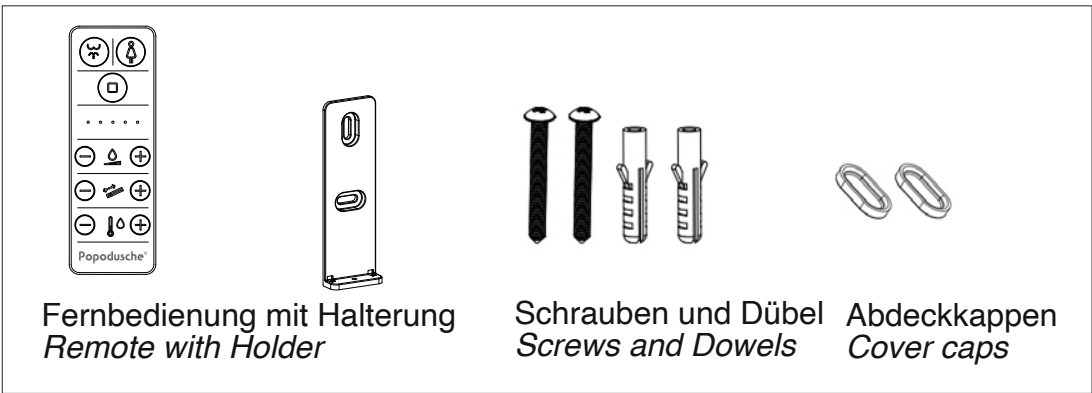
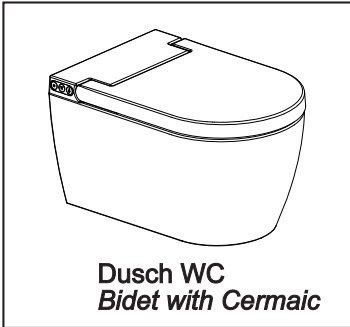

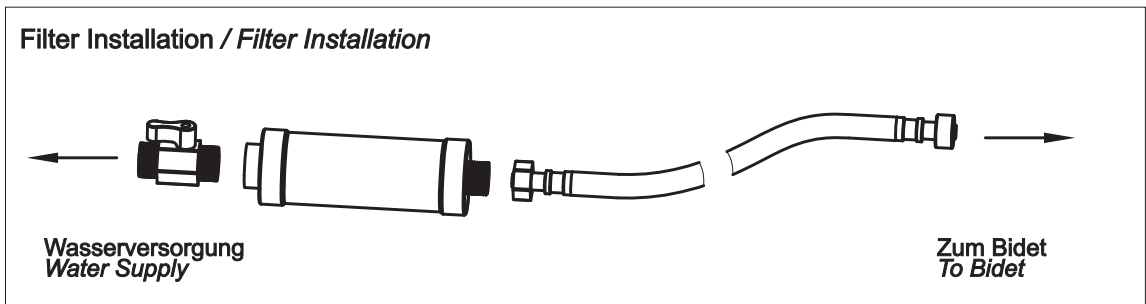
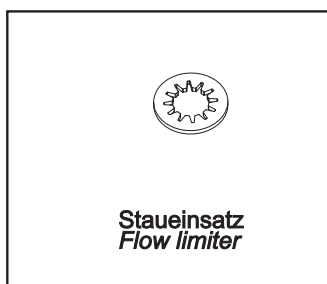
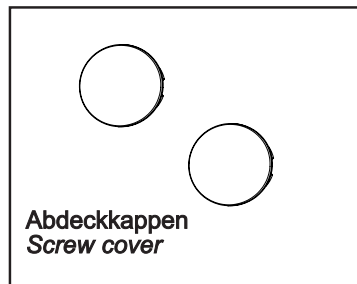
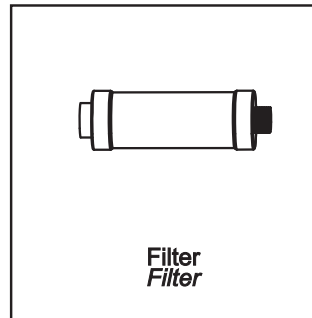
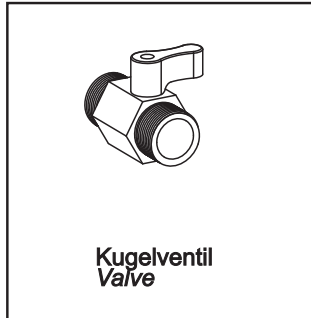
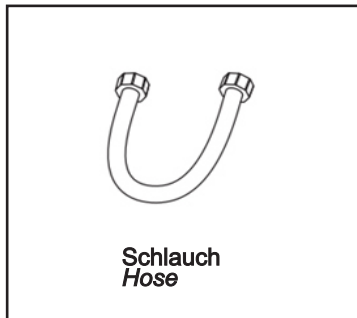
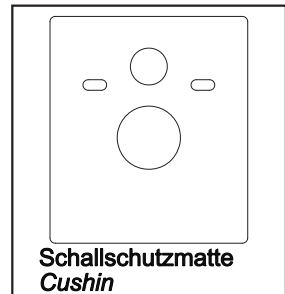
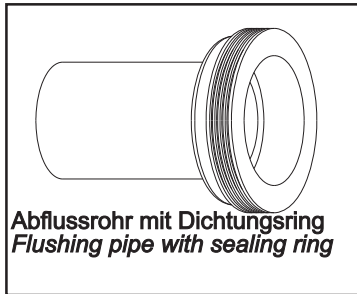

**MONTAGEWERKZEUG (NICHT IM LIEFERUMFANG ENTHALTEN)**  
*Tools (not included)*

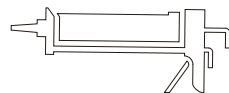
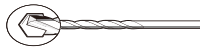
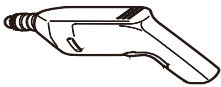
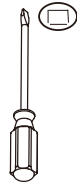
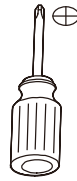
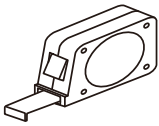

# INSTALLATION A (Strom- und Wasseranschluss ausserhalb der Keramik) INSTALLATION A (Power and Water outside of Ceramic)

Vor der Montage ist darauf zu achten, dass das Eckventil und die Stromversorgung im WC-Installationsbereich liegen.

*Prior to installation, ensure that a water valve and electrical outlet are present.*

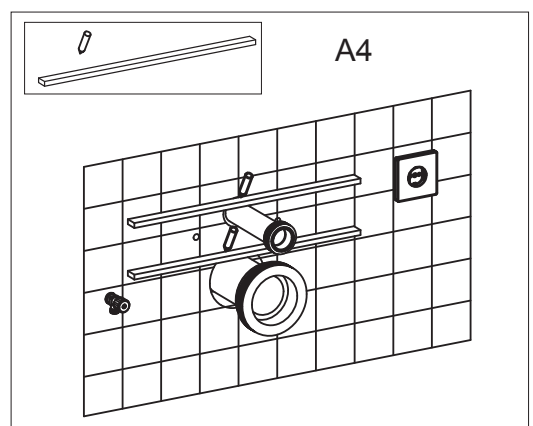
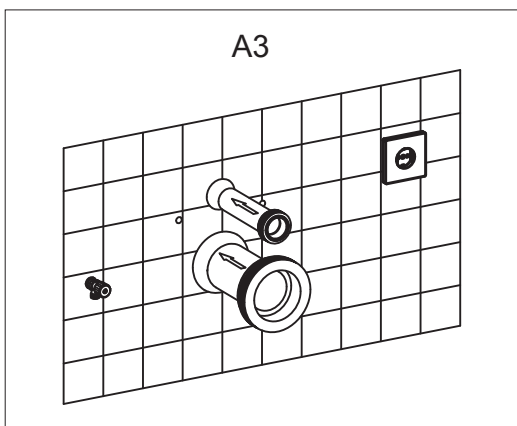
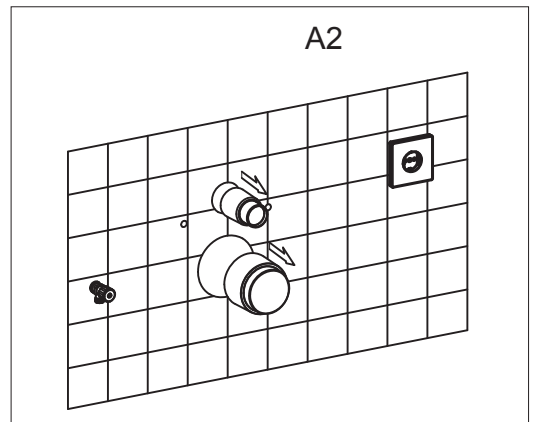
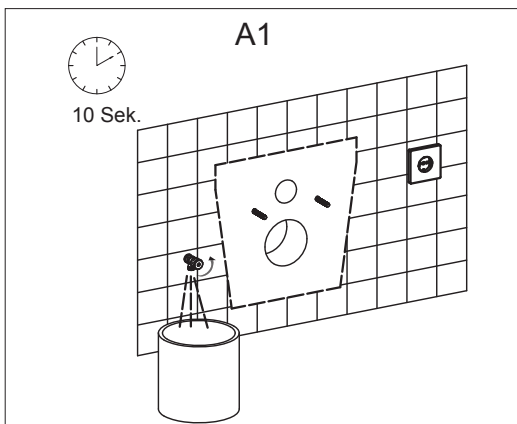
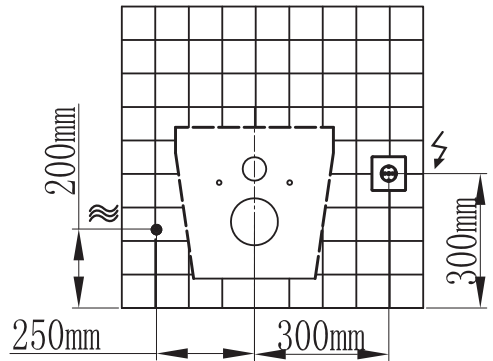

A 5

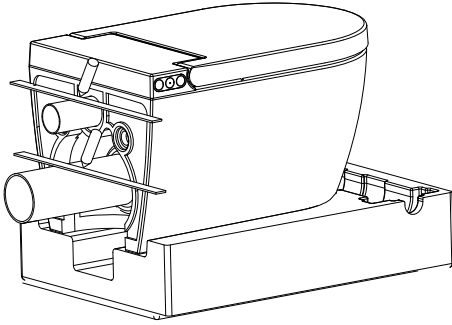

A 6

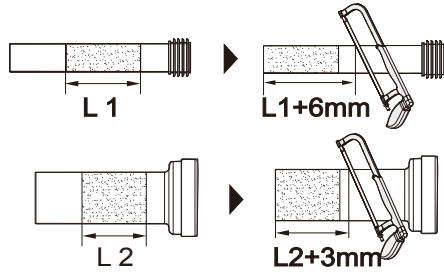

A 7

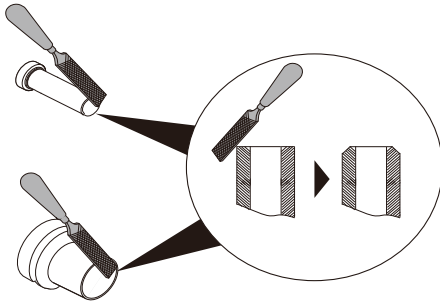

A 8

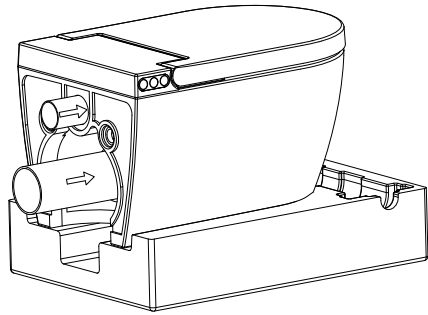

A 9

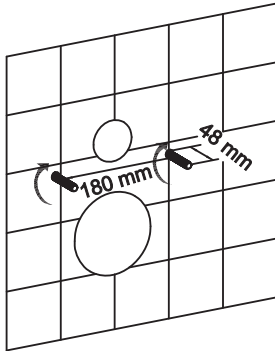

A10

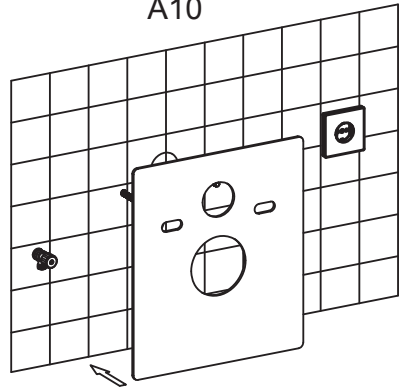

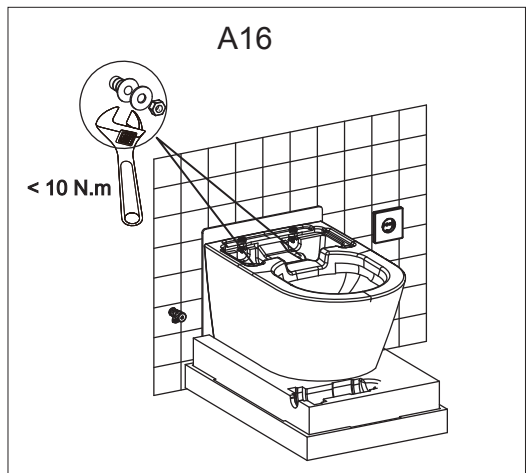
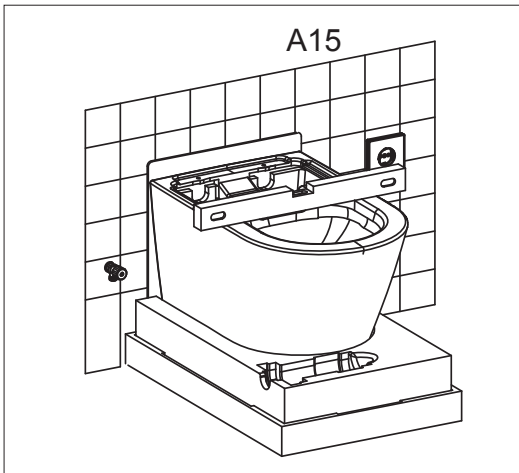
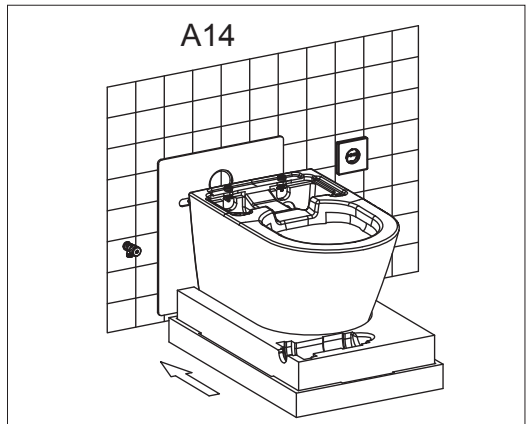
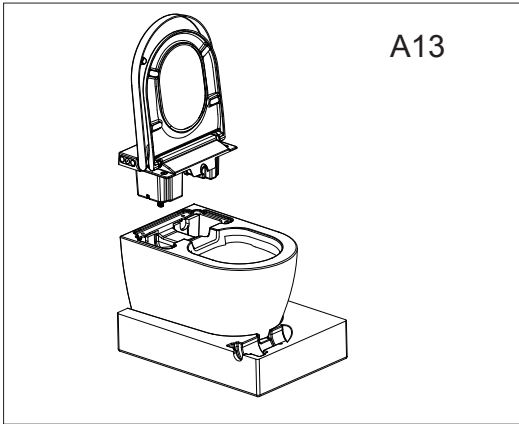
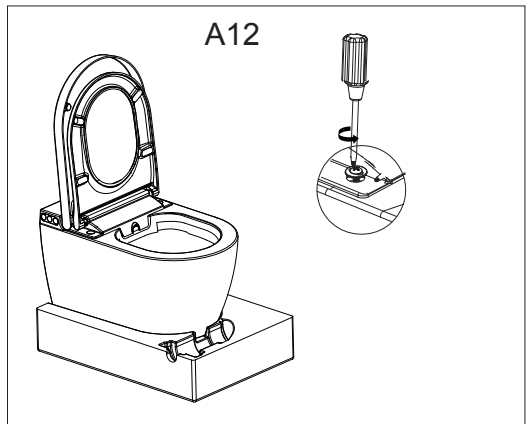
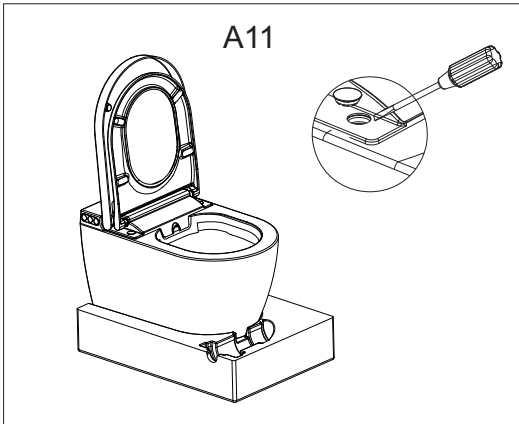



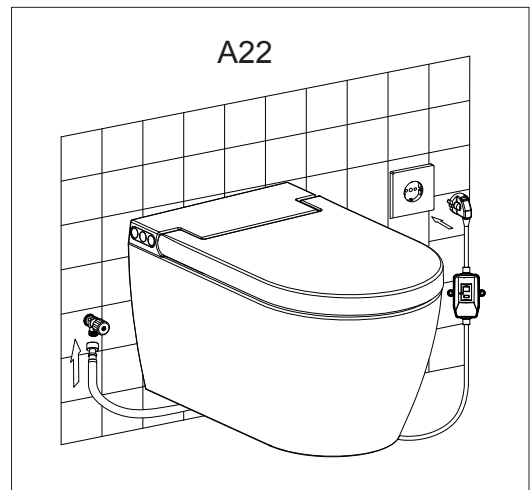
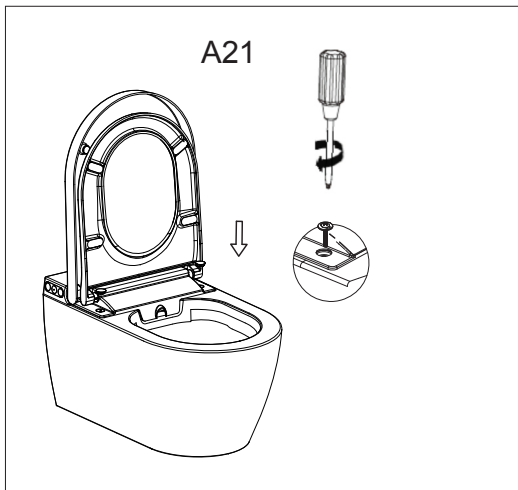
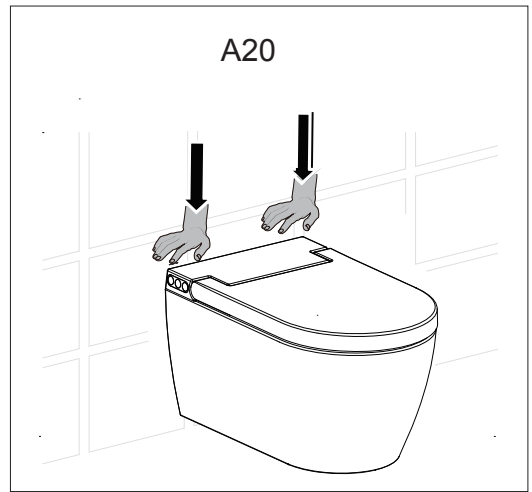
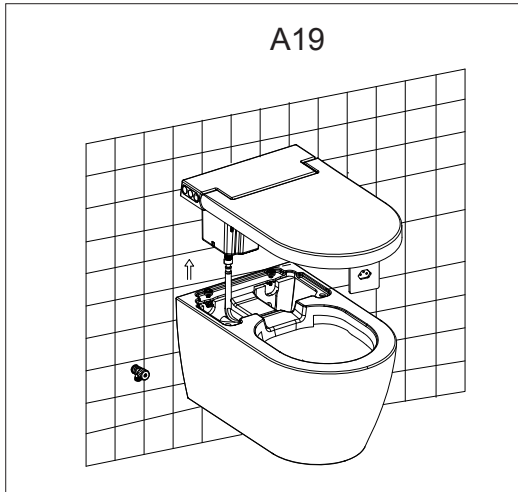
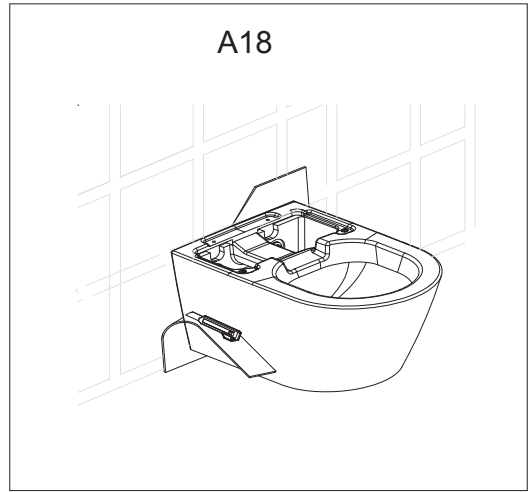
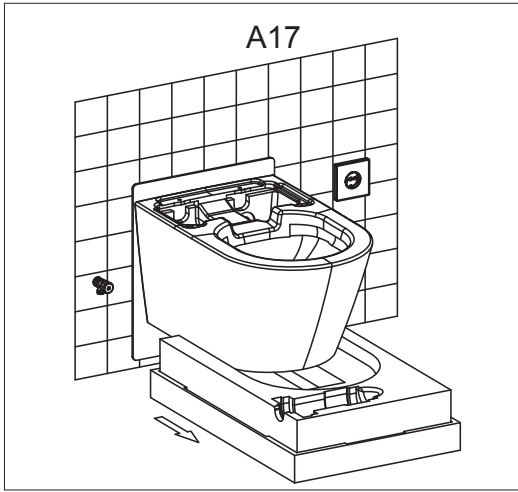

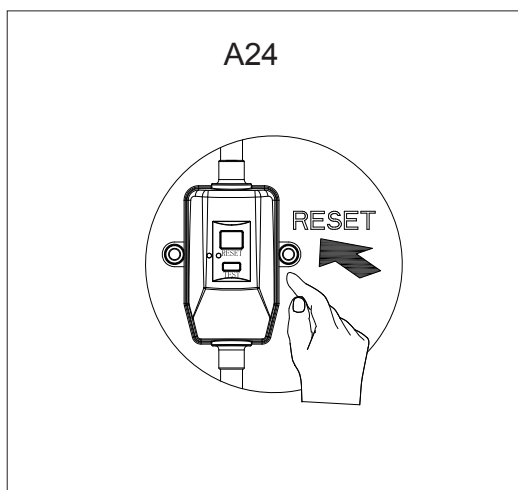
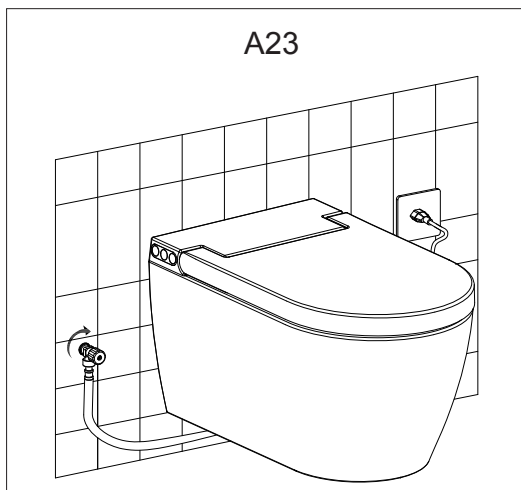

**NOTICE**

**Biegen Sie den Einlassschlauch nicht zu stark, da dies sonst zu einer zu geringen Wasseraufnahme führt.**

***Do not bend the inlet hose, otherwise it will lead to abnormal water intake***

## INSTALLATIONSMODUS B INSTALLATION MODEL B

Vor der Installation ist darauf zu achten, dass der Zulaufschlauch und das Netzkabel direkt im WC-Installationsbereich liegen.

Prior to installation, ensure that a water valve (ore Hose) and electrical outlet are installed directly behind the toilet



**Verbindungsstecker  
Coupler**



Der Elektroanschluss sollte nur von Fachpersonal durchgeführt werden.  
*The electrical connection should only be carried out by qualified personnel.*

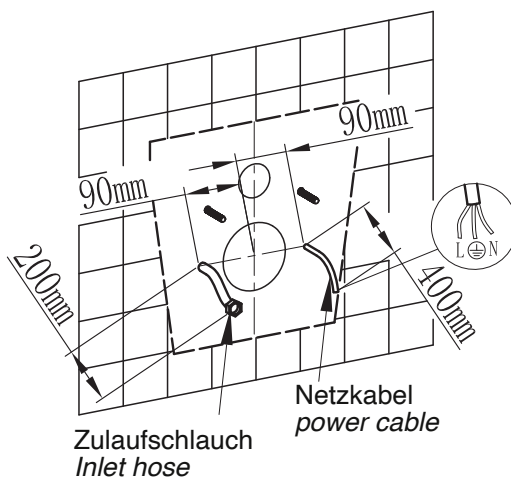

B1

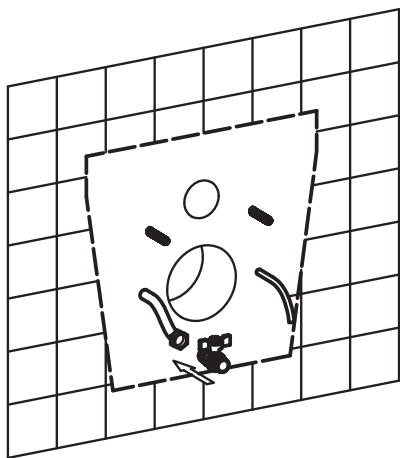

10 Sek.

B2

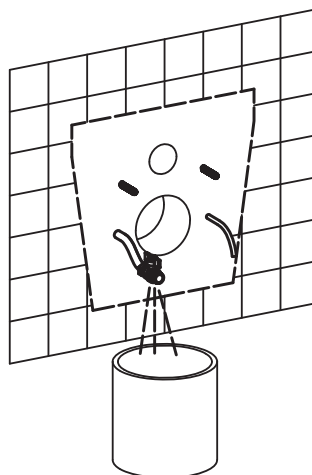

B3

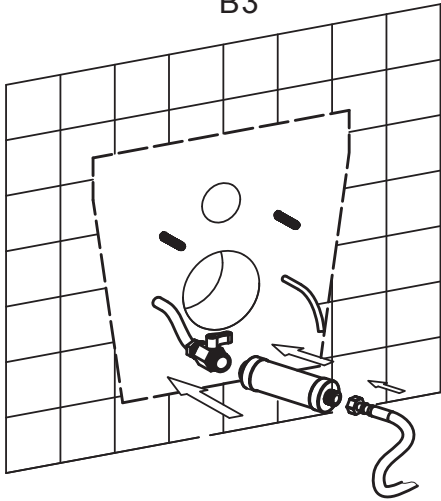

B4

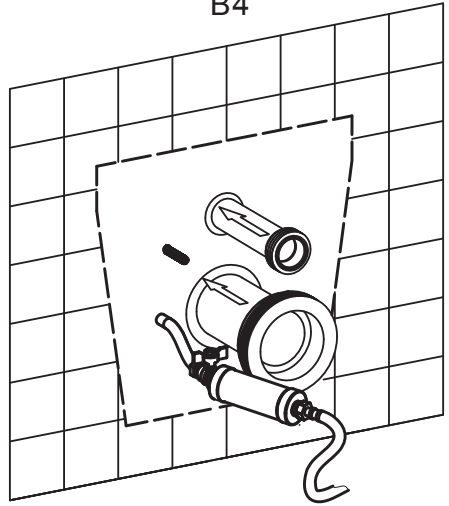

B5

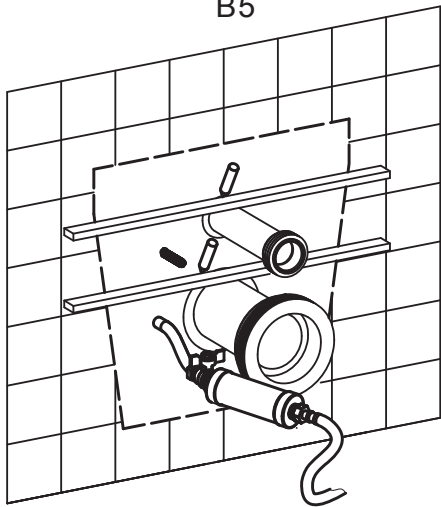

B6

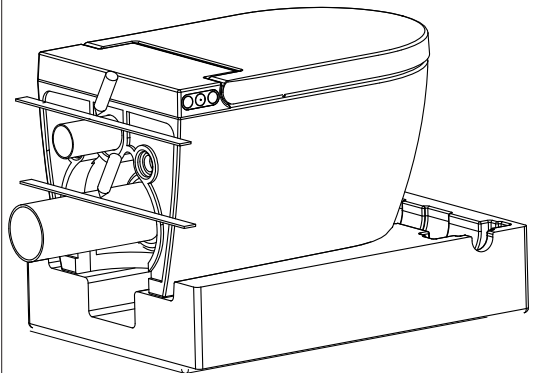

B7

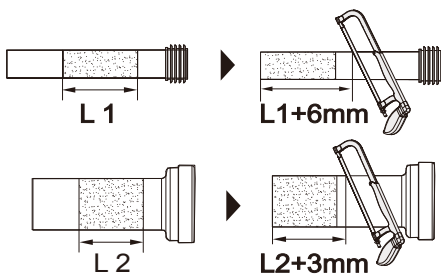

B8

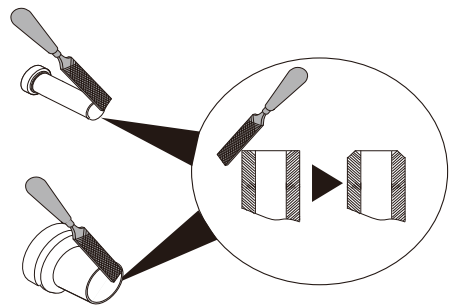

B9

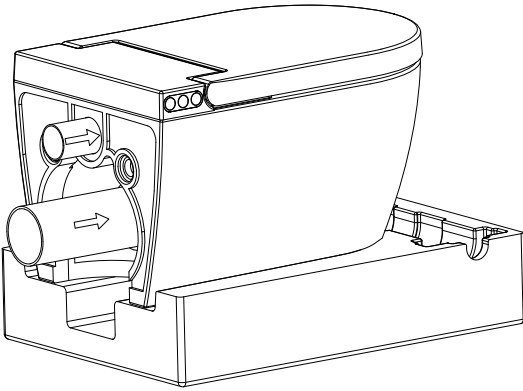

B 10

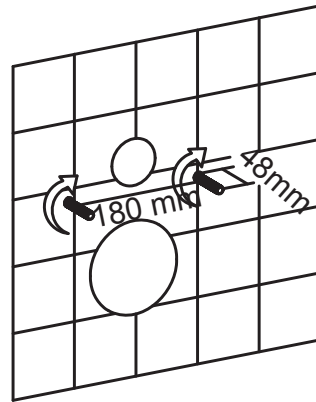

B 11

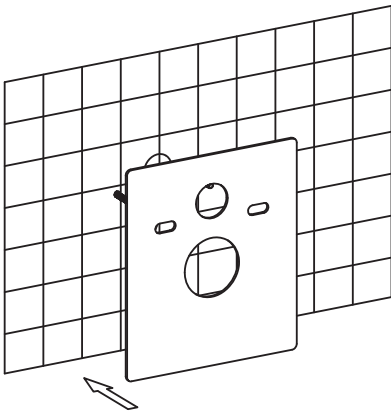

B 12

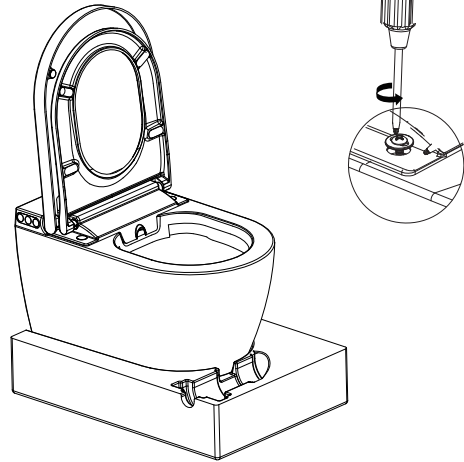

B 13

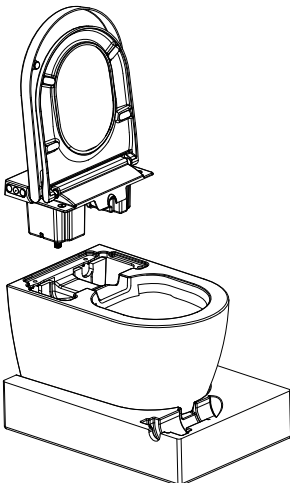

B 14

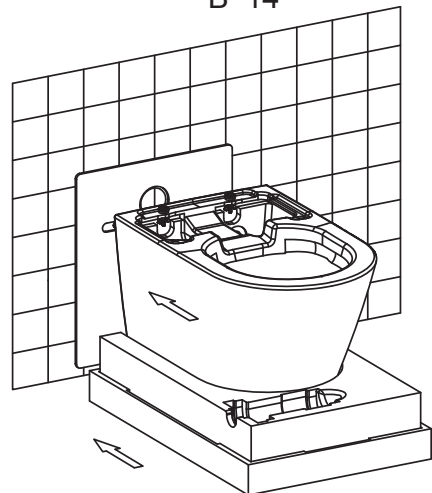

B15

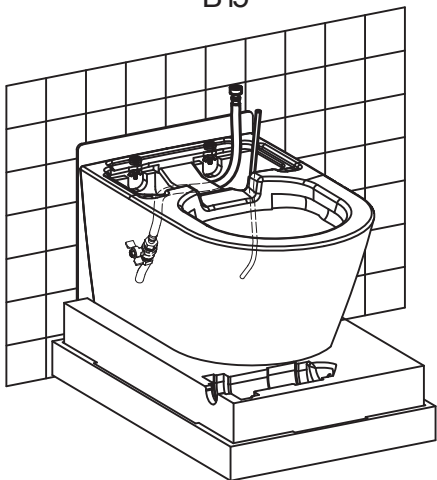

B16

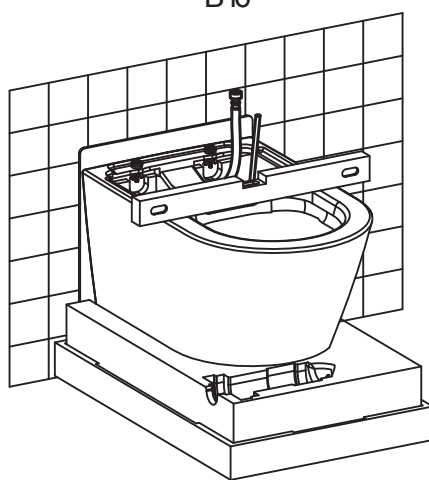

B17

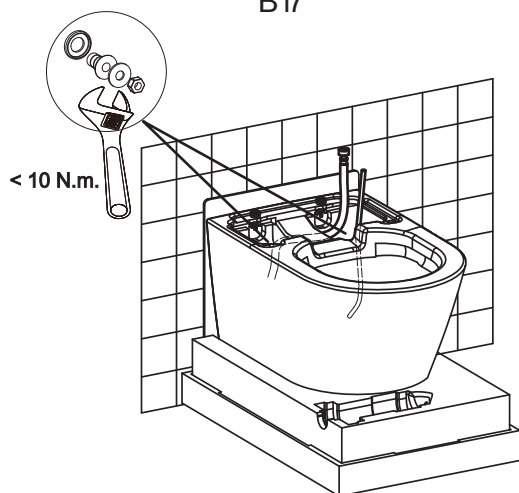

B18

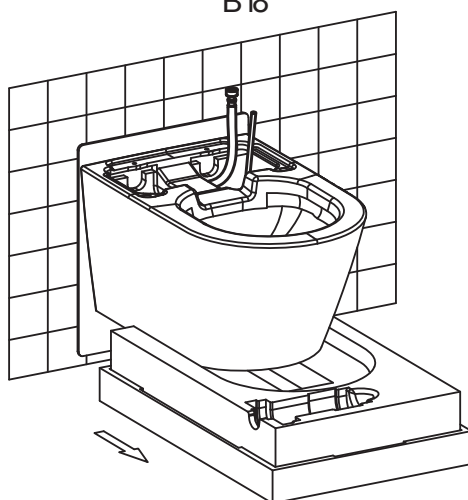

B19

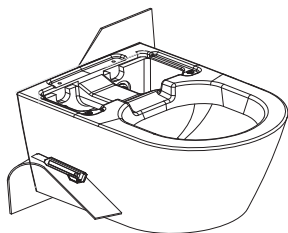

B20

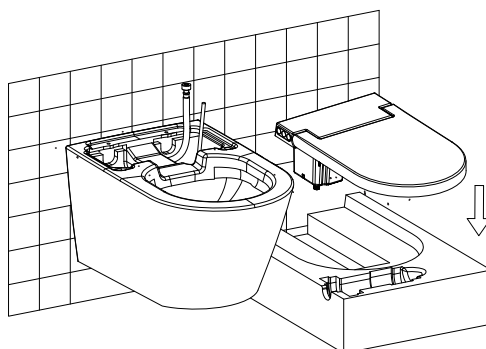

B 21

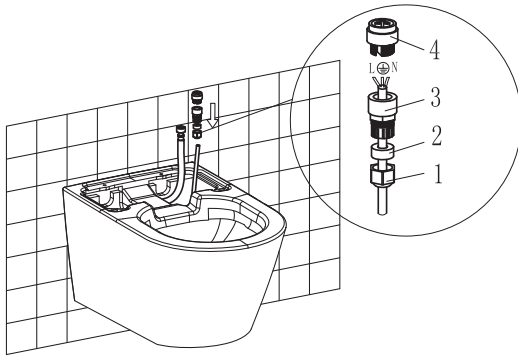

B 22

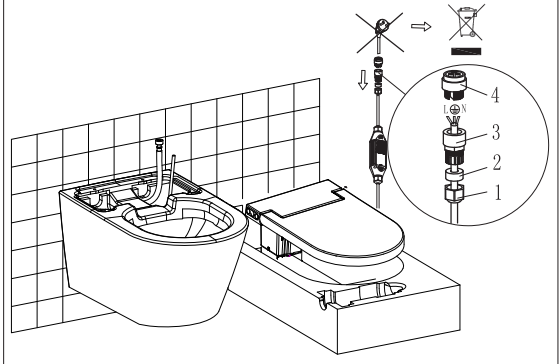

B 23

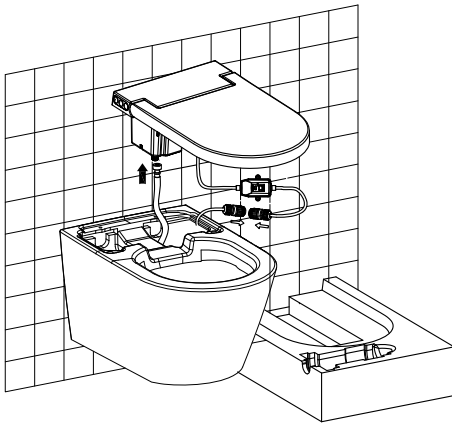

B 24

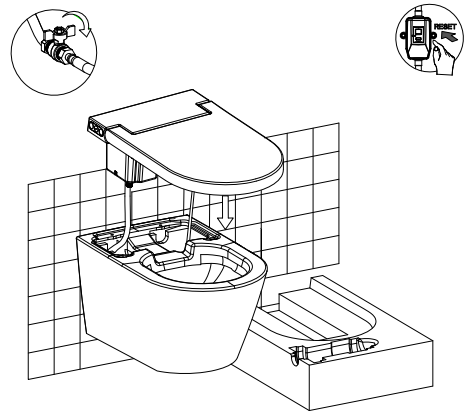

B 25

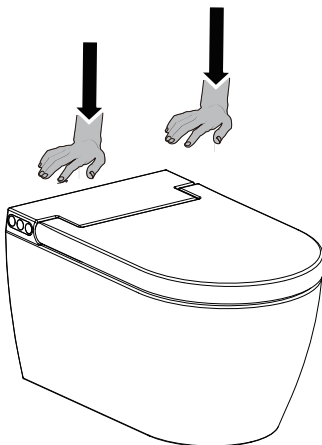

B 26

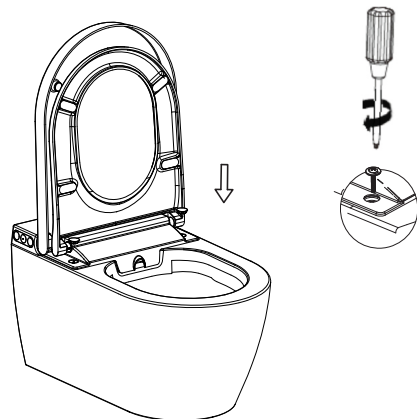

**Installation der Fernbedienung**  
*Install of the remote control*

**Empfohlener Installations Bereich**  
*Recommended installation area*

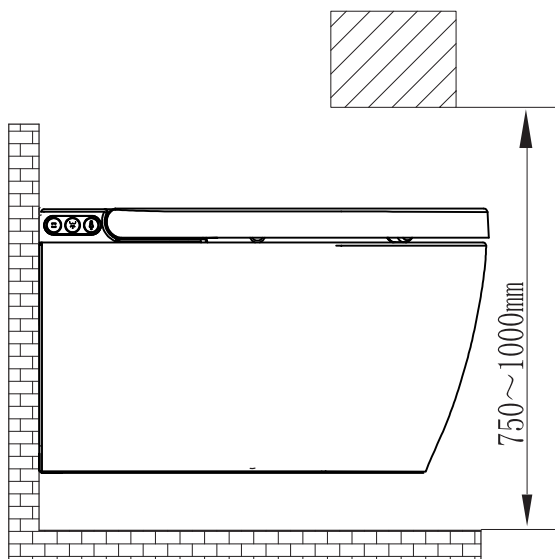
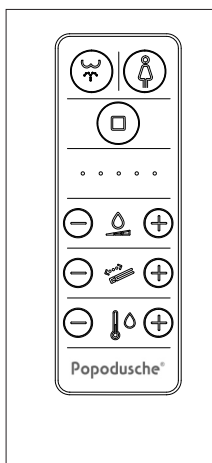

**A**

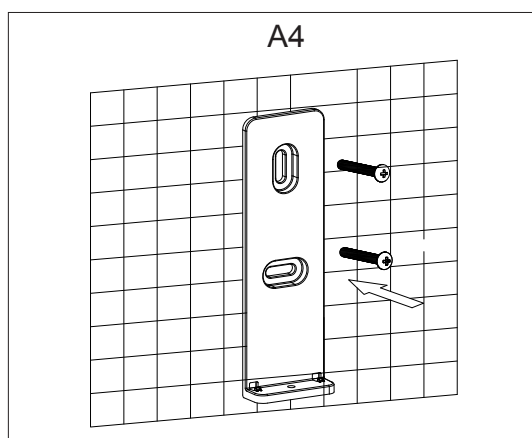
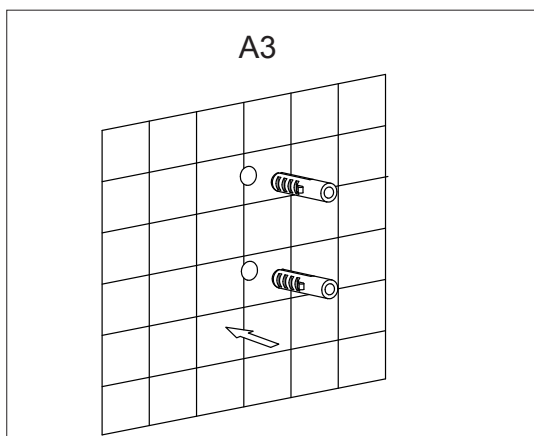
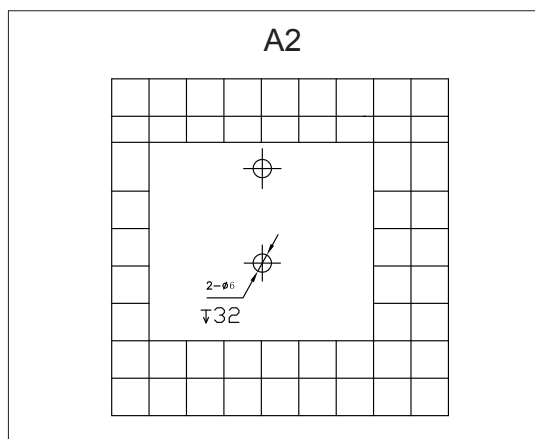
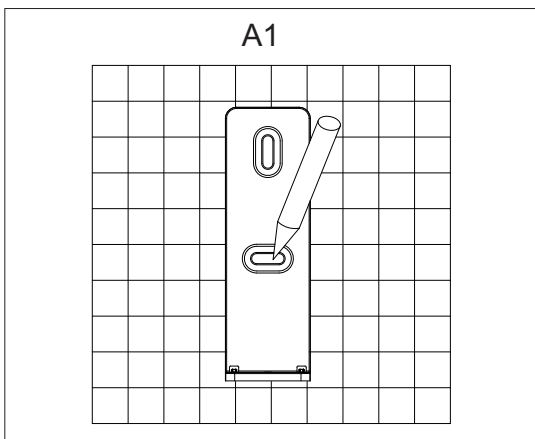



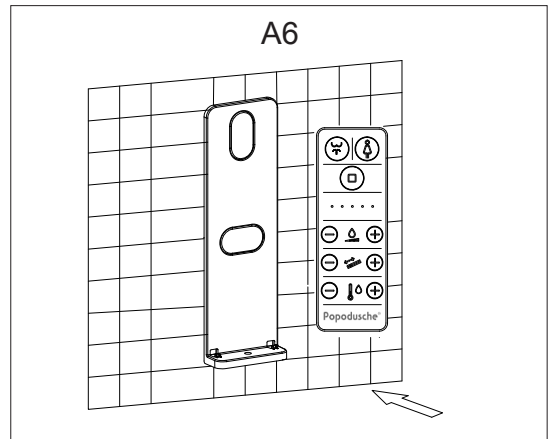
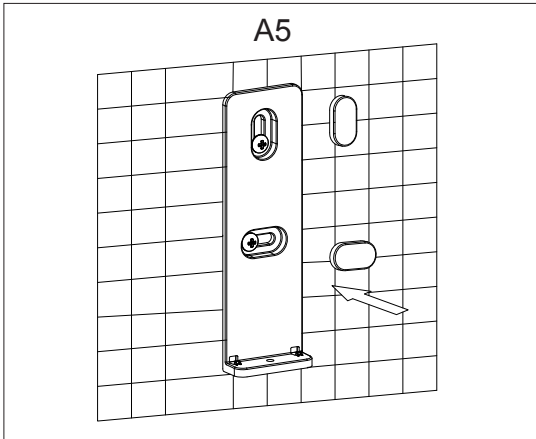

**B**

